

# MULTI V3 CABINEO FOR CONNECTOR POCKETS

Tooling Technology

Wood / Composites /  
Aluminium machining



For connector Cabineo

**Lamello**



# MULTI-SPINDLE HEAD – CLASSIC LINE

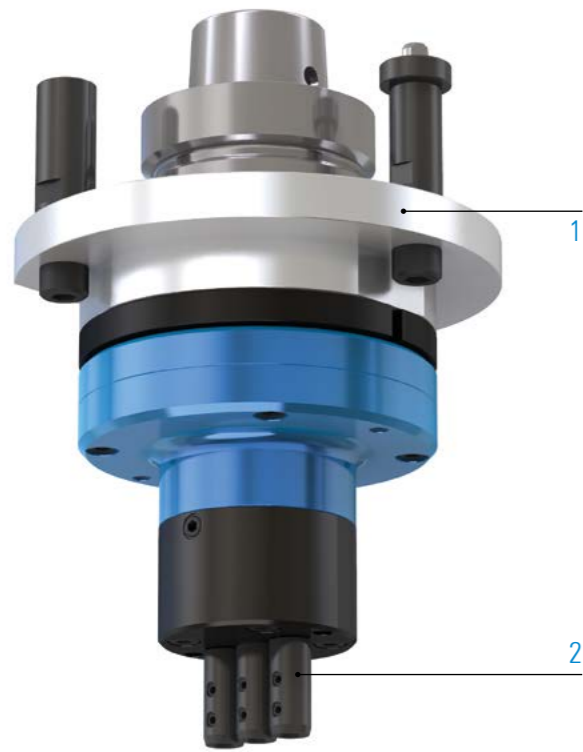

## MULTI V3 CABINEO



### TECHNICAL DATA

Lubrication	Grease
Max. drive speed $n_2$	10,000rpm
Transmission ratio ( $n_1: n_2$ )	1:1
Max. drive torque $M_2$	3Nm
Weight	about 4 kg

### STANDARD DESIGN

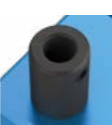
- 1  Machine connection  
HSK - F63  
Also available for other machine connections
- 2  **3** Number of spindles
-  **11,2** Spindle distance
-  Output spindle  
Weldon Ø6



The connector pockets are machined by the multi-spindle head in one single step.

## CONNECTOR CABINEO

### EASY MACHINING AND ASSEMBLY

#### MACHINING



Drilling

#### SPECIFICATIONS



Number of output spindles



Axis angle



C-angle



Grease lubrication

#### ORDER DIRECTLY



Inquiry form:  
<https://www.benztooling.com/en/products/wood-composites/tooling-technologies/request/aggregates/request?id=858>

#### Advantages of the connector Cabineo



No edge drilling



No dowel holes



One-piece and preinstalled



Fast assembly



High clamping force



Panels from 12 mm thickness

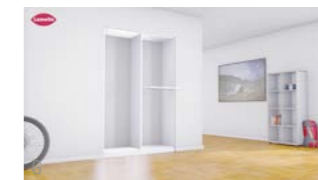

Installation of fixed shelves in assembled units



Simple, fast and strong

**BENZ GmbH Werkzeugsysteme**

Im Mühlegrün 12  
D-77716 Haslach  
T +49 7832 704-0  
F +49 7832 704-8001  
info@benztooling.com  
www.benztooling.com

